



National Fire Equipment Ltd.

Model HR Hose Rack

Features:

- Holds up to 100' (30m) of 1 1/2" (38mm) single jacket lined firehose
- Semi-automatic swing style
- Factory Mutual approved
- Positive waterstop for one person use
- Steel body with option of red powdercoat paint or chrome painting
- Zinc plated corrosion resistant pins
- Nozzle clip holder
- Max service test pressure to 150 P.S.I.
- FM Approved Project ID #: 3063544
- Note: Rack not designed for outdoor installation. For weather protection use National Fire Equipment Ltd. protective covers. NFE Model E-FHC-100.



#HR-1
Red Swing Rack



#HR-CP
Chrome Swing Rack

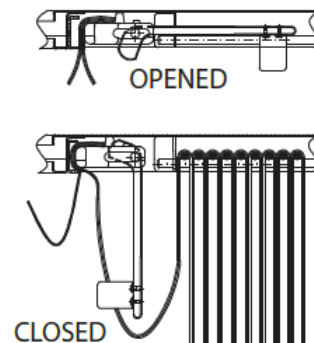
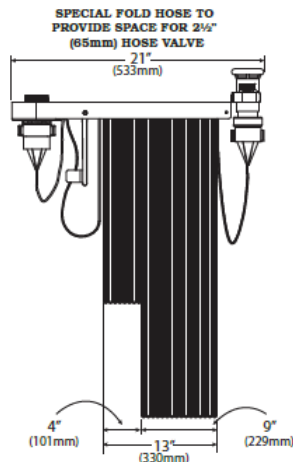
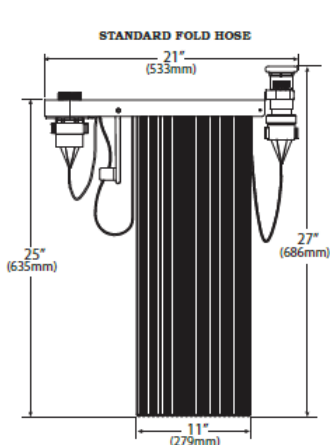

1. Open valve wide.
2. Pull hose completely off rack.
3. Pull hose to release water.
4. Turn nozzle to adjust fog pattern, straight stream or shut-off.

